

tunnel tying machine TGM 350

Meat presentation better and much quicker than done by hand.

This tunnel tying machine does away with the tiresome hand binding with meat twine. Whether meat, fish or poultry, with or without filling. The t.g.m.350 2003 guarantees optimal binding results and an attractive appearance of your product even for irregular cuts of meat.

The tunnel concept ensures a continuous flow of material. Even long roasts do not need to be turned round in order to bind them completely.

Due to the knotting after each loop, a simple portioning of the roasts is possible without the twine fraying.

The T.G.M.350 automatic even does the job automatically.

- low maintenance simple layout of components make maintenance easy
- 24Vplc control circuit with auto matic reverse cut-off clutch less braking motor
- Toggle switch for single and double binding mounted on 4 casters for mobility
- can be used for the widest variety of dimension and types of meat
- Stainless steel construction
- Water proof encapsulated electric components
- can be used in wet areas



Ficeleuse
Touwmachine
Meat tying machine
Umschnürungsmaschine

technical info

- Tunnel diameter: 320x300mm
- Performance (single): Up to 60 bindings/min
- Performance (double): 50 bindings/min
- Power requirements: 50/60 Hz, 230V 24V-PLC
- Weight circa 120 kg

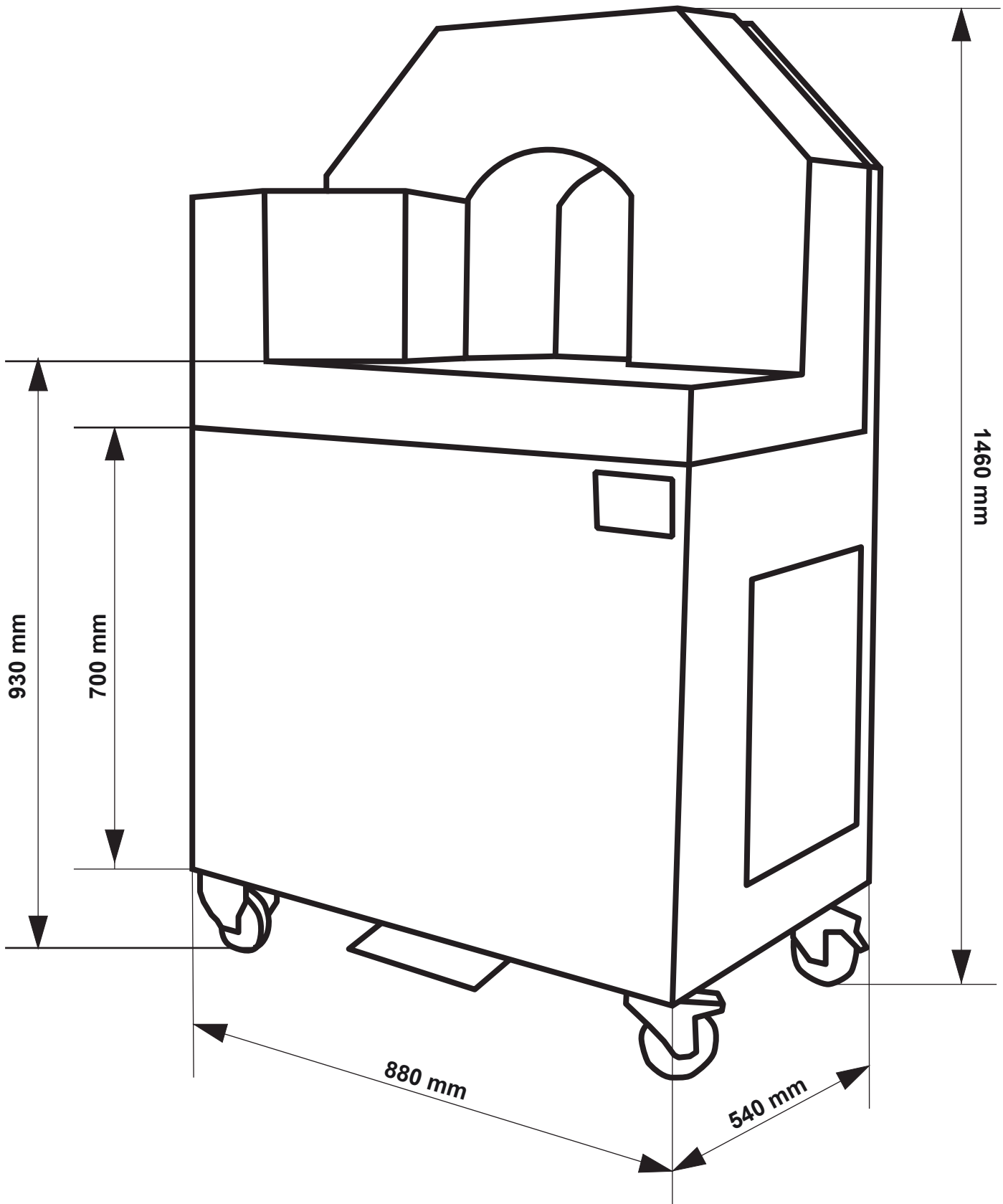

WEINERT
MASCHINENBAU
CNC FERTIGUNG

Martin Weinert Maschinenbau GmbH

Am Eisweiher 10 • D 74821 Mosbach

fon: +49 (0) 6261 - 1 80 74 22 • fax: +49 (0) 6261 - 1 80 74 23

eMail: martin.weinert@mweinert.de